

02	ORG. DE BASE BOITE DE VITESSES
	GEARBOX BASIC COMPONENT
	GRUNDORGAN GETRIEBE

53	ORGANE BOITE DE VITESSES
	GEARBOX COMPONENT
	ORGAN GETRIEBE

203	BOITE DE VITESSES B. 152
	GEARBOX B. 152
	GETRIEBE B. 152

CATALOGUE RELEVÉ AU : 5 - 6 - 72
boîte de vitesses N° 4047

CATALOG ACCOUNTING AS OF 5-6-72
Gearbox N° 4047

KATALOGAUSZUG ZUM 5 - 6 - 72
Getriebe Nr. 4047

02	53	203	N° EDITION CATALOGUE	N° DE PLANCHE
1	2	3	4	5

Carter et couvercles de boîte de vitesses	00	01
<i>Gearbox, casing and covers</i>		
<i>Getriebe, Gehäuse und Deckel</i>		
Pignons de boîte de vitesses	00	02
<i>Gearbox gears</i>		
<i>Zahnräder und wellen des Getriebes</i>		
Couvercle supérieur, coulisseaux, fourchettes	00	03
<i>Top lids, shifter shafts, fork</i>		
<i>Obere Getriebegehäuse Deckel, Gleitbacken, Gabeln</i>		
Carter d'embrayage, butée fourchette (12 LF 45)	00	04
<i>Clutch housing, clutch thrust bearing, fork (12 LF 45)</i>		
<i>Kupplungsgehäuse, Kupplungsausrücklager, Gabel (12 LF 45)</i>		
Carter d'embrayage, butée, fourchette (14" B.B.)	00	05
<i>Clutch housing, clutch thrust bearing, fork (14" B.B.)</i>		
<i>Kupplungsgehäuse, Kupplungsausrücklager, Gabel (14" B.B.)</i>		

1	ORGANE DE BASE	BASIC COMPONENT	GRUND-ORGAN
2	ORGANE	COMPONENT	ORGAN
3	TYPE D'ORGANE	COMPONENT TYPE	ORGANTYP
4	N° ÉDITION	CATAL. EDITION NUMBER	NUMMER DER AUSGABE
5	N° PLANCHE	PLATE NUMBER	BILD Nr.
6	REPÈRE	MARKING	KENNZIFFER

7	N° PIÈCE	PART N°	TEIL Nr.
8	DÉSIGNATION	DESIGNATION	BESCHRIFTUNG
9	QUANTITÉ	QUANTITY	MENGE
10	CODE OBSERVATIONS	CODE OF OBSERV.	ANMERKUNGEN KODE
11	DÉTAILS OBSERVATIONS	DETAILS OF OBSERV.	ANMERKUNGEN BEDEUT.

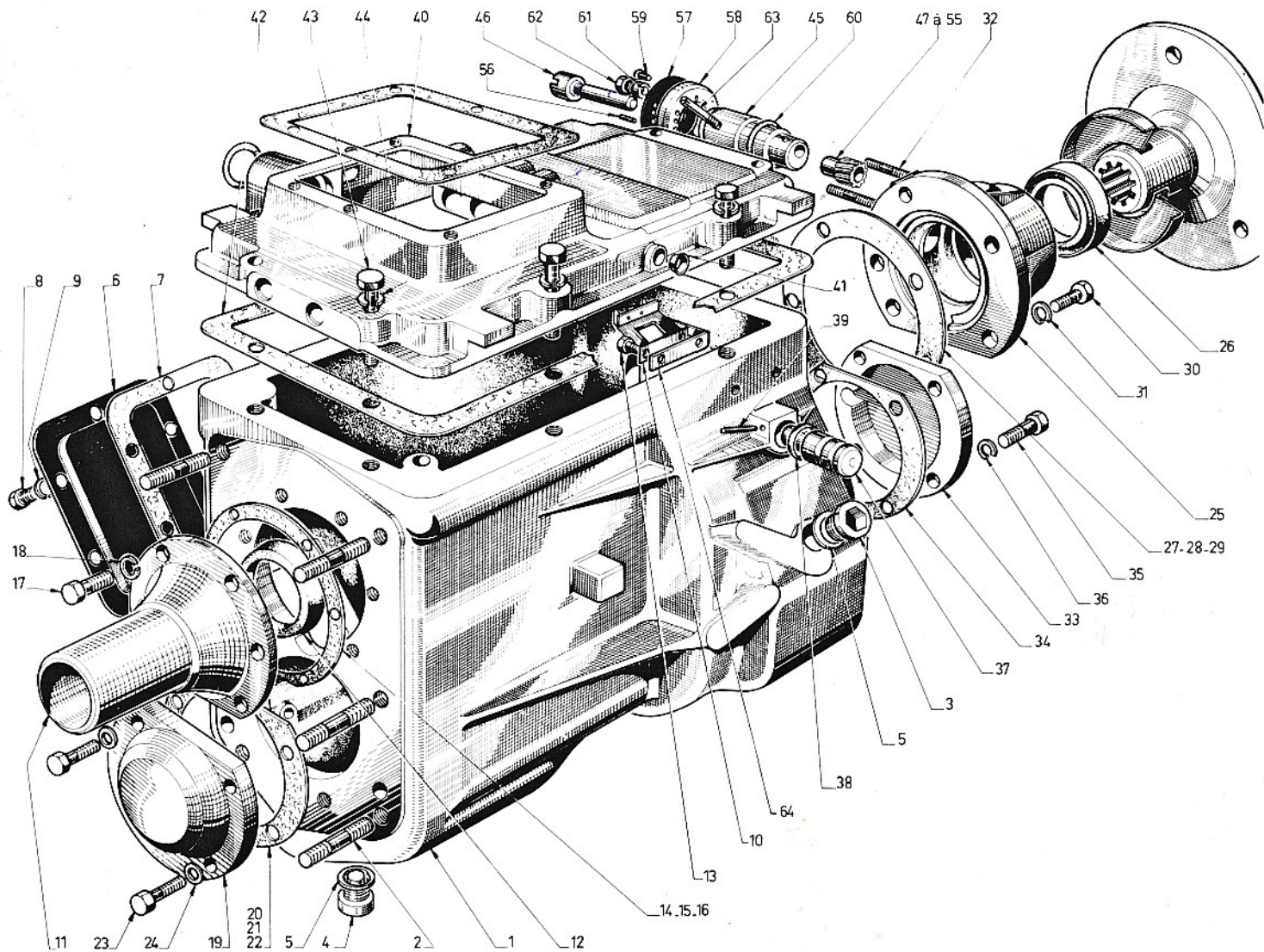

02	53	203	00	01
1	2	3	4	5

6	7	8	9	10
1	61298491	CARTER	1	
2	61218821	GOUJON	6	
3	61436503	BOUCHON	1	
4	61251117	BOUCHON	1	
5	61238497	JOINT	2	
6	61700831	COUVERCLE	1	
7	61700832	JOINT	1	
8	61803145	VIS D 10 L 20	6	
9	61815246	GROWER DE 10	6	
10	61225276	FREIN	1	
11	61224753	TROMPETTE	1	
12	61231618	JOINT	1	
13	61803105	VIS D 8 L 20	2	
14	61215944	JOINT EP 0 3		68
15	61215945	JOINT EP 0 4		68
16	61215946	JOINT EP 0 5		68
17	61803109	VIS D 8 L 30	6	
18	61815224	GROWER DE 8	6	
19	61215514	COUVERCLE	1	
20	61215940	JOINT EP 0 3		68
21	61215941	JOINT EP 0 4		68
22	61215942	JOINT EP 0 5		68
23	61803109	VIS D 8 L 30	4	
24	61815224	GROWER DE 8	4	
25	61298492	COUVERCLE	1	

6	7	8	9	10
26	61254122	JOINT	1	
27	61219922	JOINT EP 0 3		68
28	61219923	JOINT EP 0 4		68
29	61219924	JOINT EP 0 5		68
30	61803149	VIS D 10 L 30	5	
31	61815225	GROWER DE 10	5	
32	61406149	GOUJON	2	
33	61224834	COUVERCLE	1	
34	61215939	JOINT	1	
35	61803109	VIS D 8 L 30	4	
36	61815224	GROWER DE 8	4	
37	61227602	PIVOT	1	
38	61251060	JOINT	1	
39	61701446	GOUPILLE	1	
40	61217921	CARTER	1	
41	61488011	BOUCHON	1	
42	61216159	JOINT	1	
43	61803112	VIS D 8 L 45	8	
44	61815224	GROWER DE 8	8	
45	61239894	COUSSINET	1	
46	61219926	AXE	1	
47	61219891	PIGNON 14 D	1	
48	61219892	PIGNON 15 D	1	
49	61219893	PIGNON 16 D	1	
50	61219894	PIGNON 17 D	1	

10	11
0068	Quantités : au choix Quantities : as desired Mengen : nach Wahl

10	11

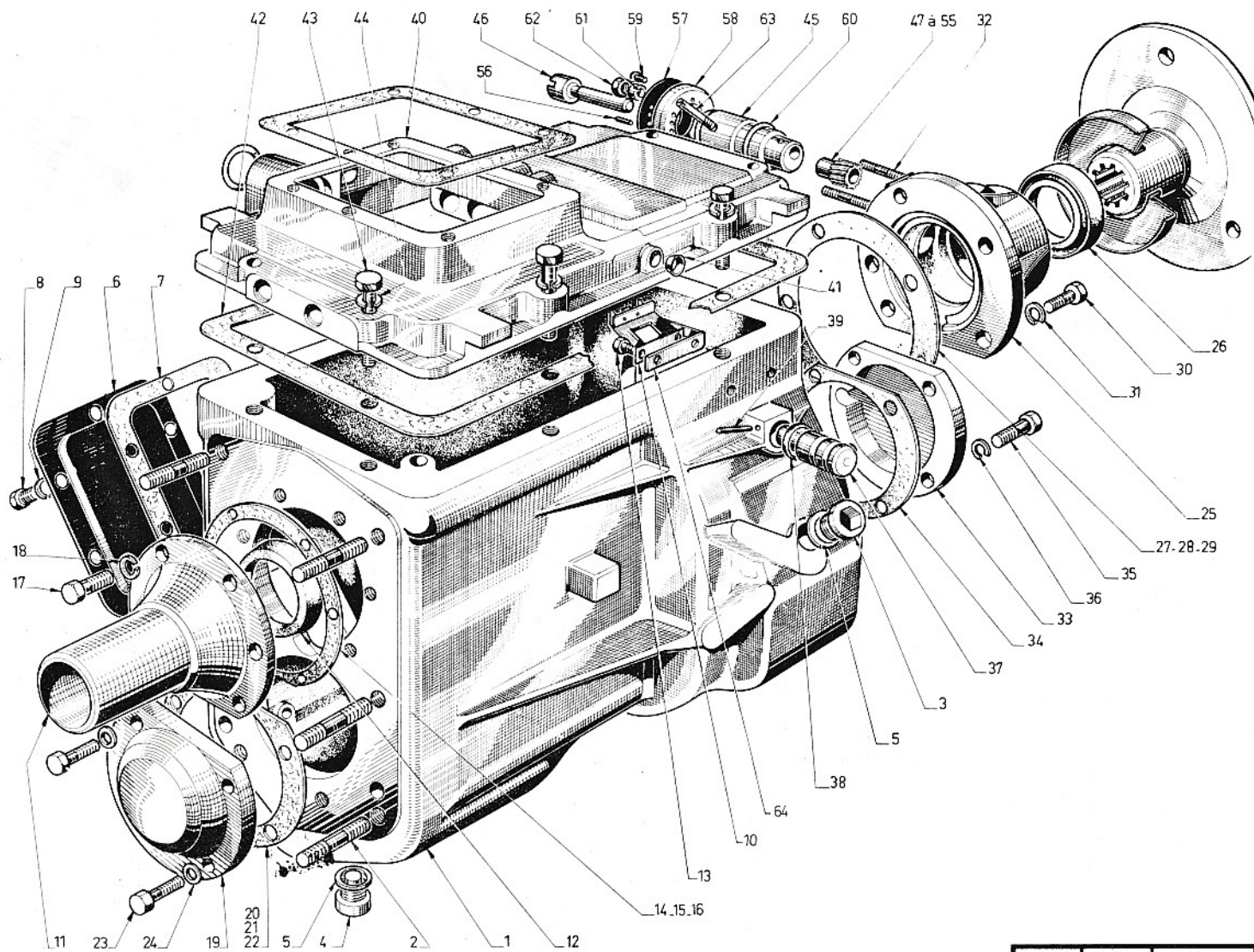

02	53	203	00	01
1	2	3	4	5

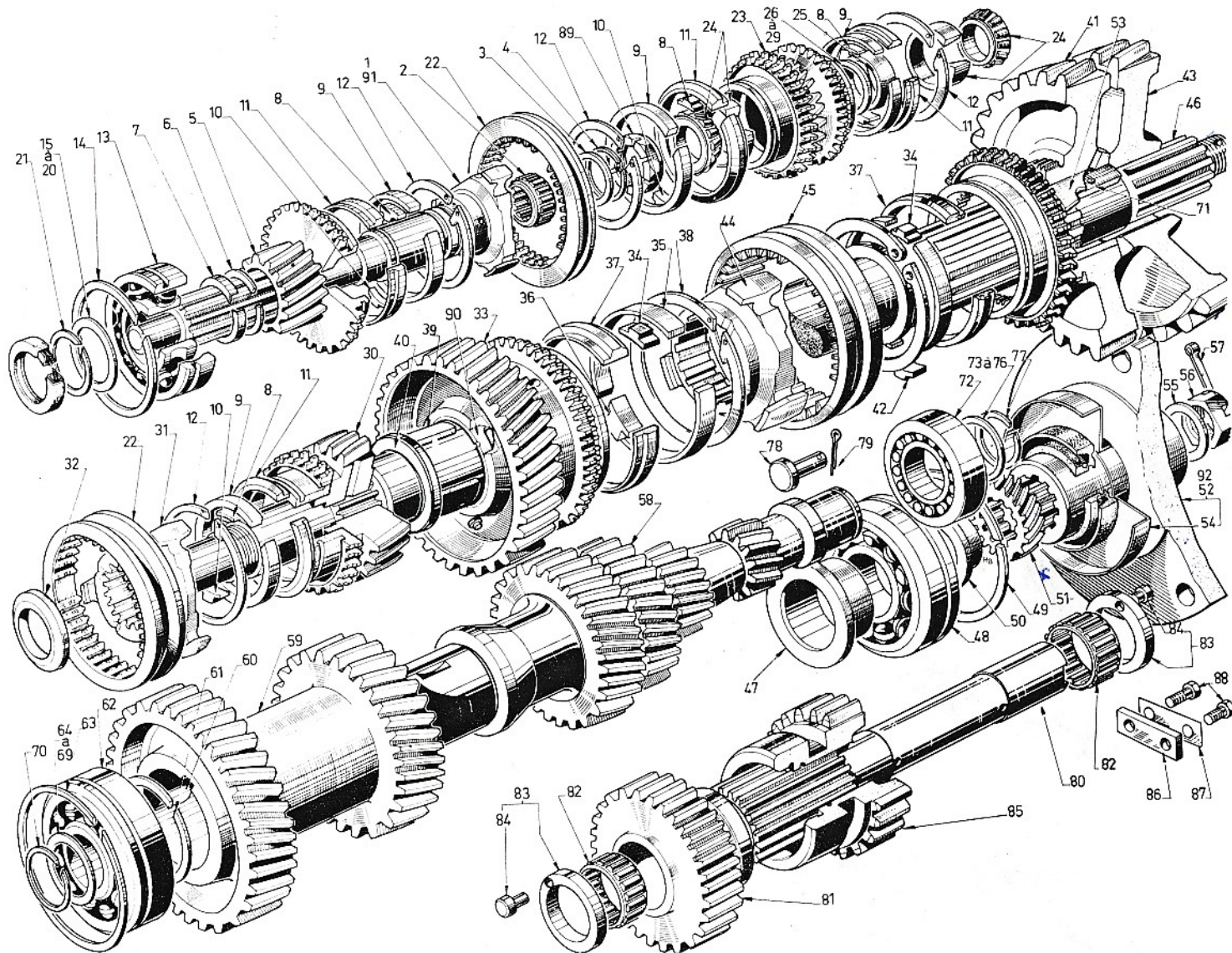

02	53	203	00	02
1	2	3	4	5

6	7	8	9	10
1	61234567	APBRE CP3	1	486
2	61204079	ROULEMENT	1	
3	61217928	RONDELLE	1	
4	61204032	JONC	1	
5	61293460	PIGNON	1	
6	61232025	DEMI BUTEE	2	
7	61232024	CAGE	1	
8	61215386	TAQUET	3	
9	61215382	RESSORT	4	
10	61215383	BUTEE	3	
11	61219120	ANNEAU	3	
12	61215388	JONC	1	
13	61204025	ROULEMENT	1	
14	61204026	SEGMENT	1	
15	61215602	RONDELLE EP 14		68
16	61215603	RONDELLE EP 15		68
17	61215604	RONDELLE EP 16		68
18	61215605	RONDELLE EP 17		68
19	61216414	RONDELLE EP 18		68
20	61216415	RONDELLE EP 19		68
21	61215644	SEGMENT	1	
22	61234569	MANCHON	1	
23	61291160	PIGNON	1	
24	61204028	ROULEMENT	2	
25	61216509	ENTRETOISE	1	

6	7	8	9	10
26	61216505	CALE EP 0 1		68
27	61216506	CALE EP 0 2		68
28	61216507	CALE EP 0 3		68
29	61216508	CALE EP 0 05		68
31	61234568	MOYEU	1	
32	61221126	RONDELLE	1	
33	61664732	PIGNON	1	
34	61215385	TAQUET	2	
35	61218552	RESSORT	2	
36	61215384	BUTEE	1	
37	61218553	ANNEAU	2	
38	61215380	JONC	1	
39	61664954	BAGUE	1	
40	61221870	RONDELLE	1	
41	61298300	PIGNON	1	
42	61215387	BUTEE	1	
43	61224639	PIGNON	1	
44	61226370	MOYEU	1	
45	61231340	MANCHON	1	
46	61221869	ARBRE	1	
47	61221880	ENTRETOISE	1	
48	61204025	ROULEMENT	1	
49	61204026	SEGMENT	1	
50	61219947	ENTRETOISE	1	
51	61239931	VIS	1	

10	11
0068	Quantités : au choix Quantities : as desired Mengen : nach Wahl
0486	Avec moteur CP 3 With motor CP 3 Mit Motor CP 3

10	11

02	53	203	00	02
1	2	3	4	5



DÉSIGNATION PLANCHE : SE RÉFÉRER AUX PAGES "SOMMAIRE"
 PLATE DESIGNATION : REFER TO FLYLEAF
 BILDBESCHRIFTUNG : SIEHE VORSATZBLÄTTER



6	7	8	9	10
52	61290983	BRIDE	1	
53	61221472	BAGUE	1	
54	61216258	DEFLECTEUR	1	
55	61227209	RONDELLE	1	
56	61215859	ECROU	1	
57	61405769	GOUPILLE	1	
58	61221866	ARBRE	1	
59	61216431	PIGNON	1	
60	61215630	CLAVETTE	1	
61	61215641	SEGMENT	1	
62	61703247	ROULEMENT	1	
63	61703248	SEGMENT	1	
64	61215817	RONDELLE EP 14		68
65	61215818	RONDELLE EP 15		68
66	61215819	RONDELLE EP 16		68
67	61215820	RONDELLE EP 17		68
68	61218045	RONDELLE EP 18		68
69	61218046	RONDELLE EP 19		68
70	61215643	SEGMENT	1	
71	61299636	BAGUE	1	
72	61204027	ROULEMENT	1	
73	61215817	RONDELLE EP 14		68
74	61215818	RONDELLE EP 15		68
75	61215819	RONDELLE EP 16		68
76	61215820	RONDELLE EP 17		68

6	7	8	9	10
77	61215643	SEGMENT	1	
78	61224813	AXE	1	
79	61819911	GOUPILLE	1	
80	61217684	AXE	1	
81	61221867	PIGNON	1	
82	61204009	ROULEMENT	1	
83	61292097	RONDELLE	2	
84	61217686	ERGOT	2	
85	61224640	PIGNON	1	
86	61215851	PLAQUETTE	1	
87	61215852	FREIN	1	
88	61404587	VIS	2	
89	61217946	ECROU	1	
90	61233788	BAGUE	1	
91	61234556	ARBRE M32S	1	
92	61290984	BRIDE M32S	1	

10	11
0068	Quantités : au choix Quantities : as desired Mengen : nach Wahl

10	11

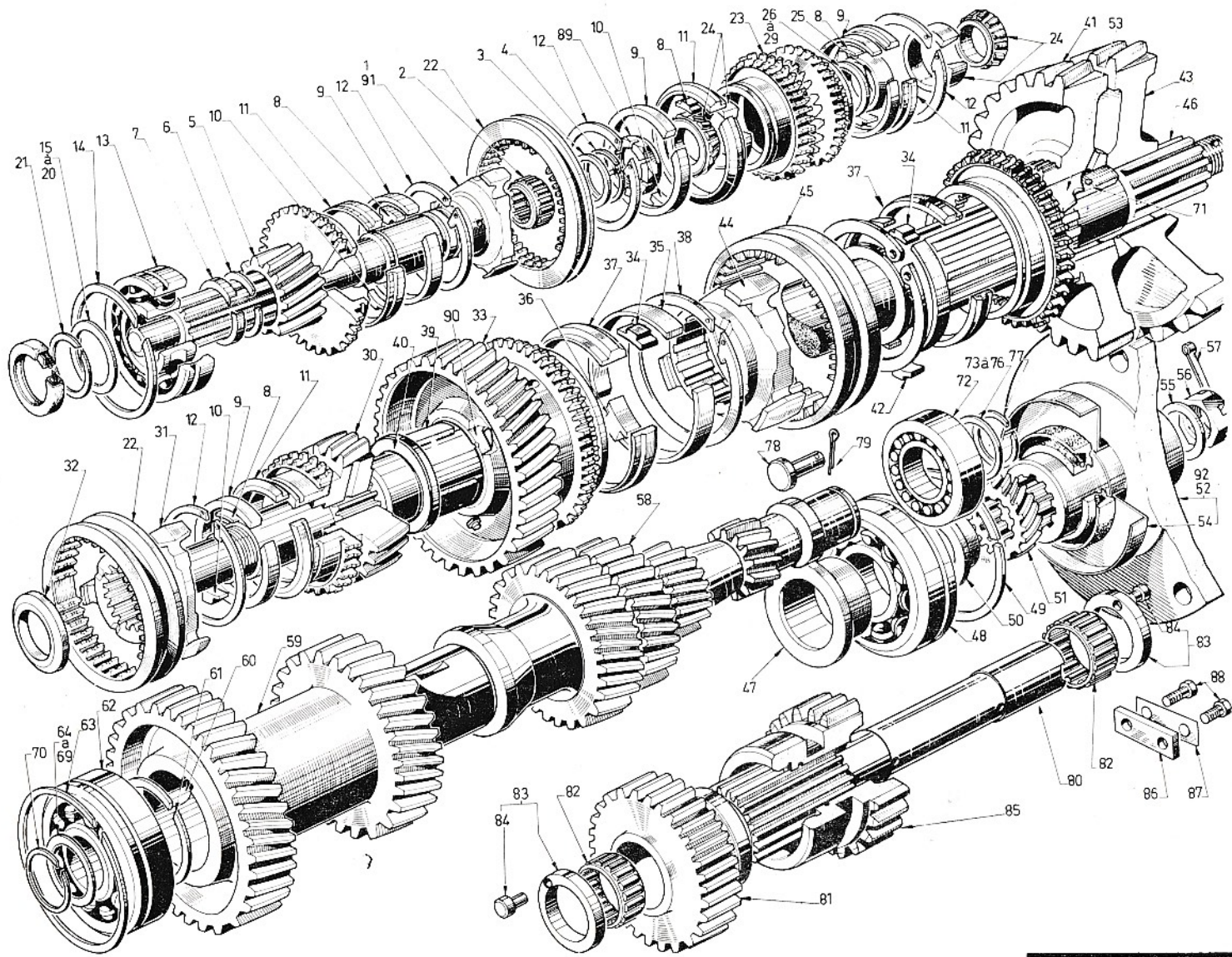

02	53	203	00	02
1	2	3	4	5

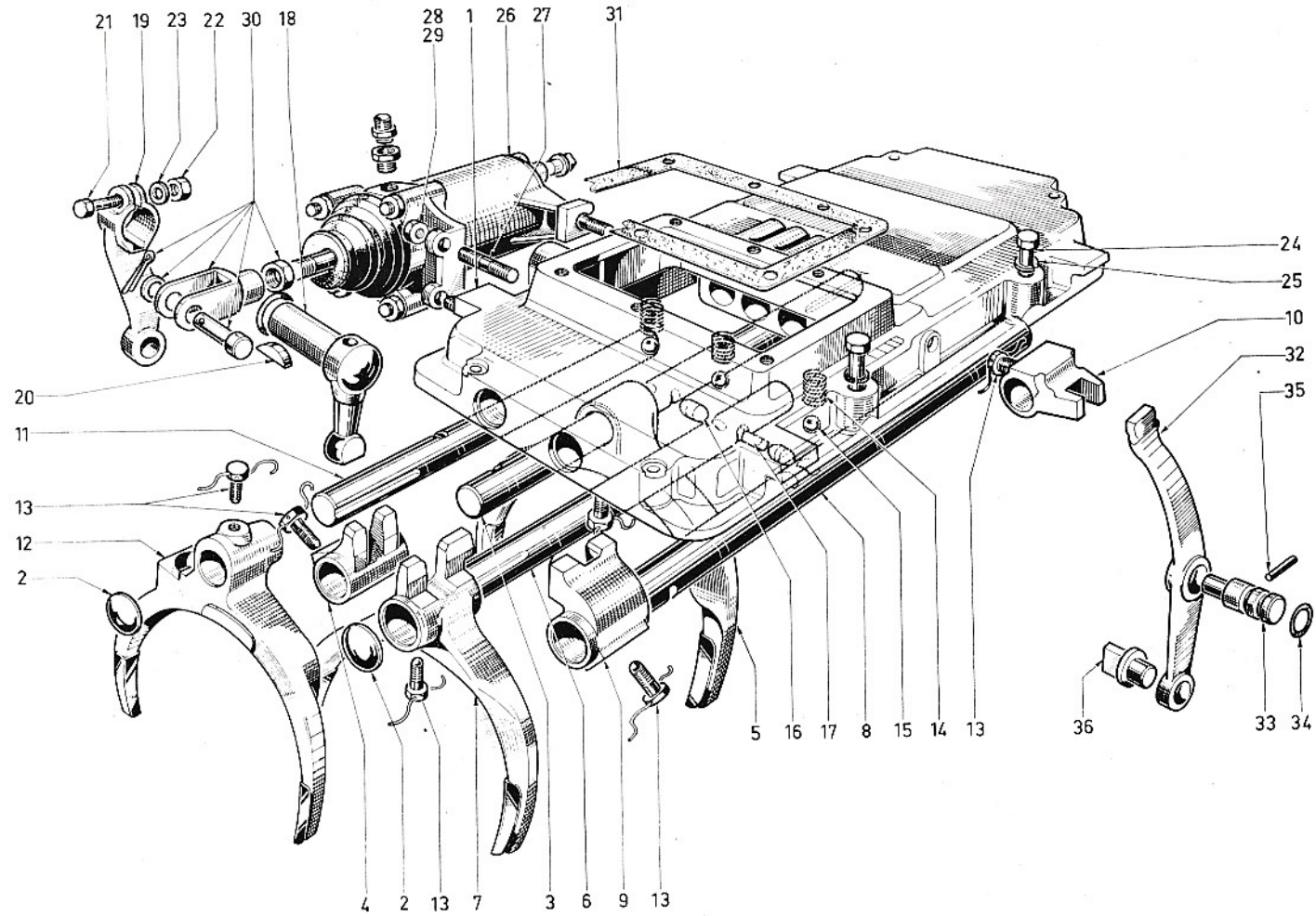

02	53	203	00	03
1	2	3	4	5

6	7	8	9	10
1	61217921	CARTER	1	
2	61410375	BOUCHON	4	
3	61227196	COULISSEAU 1 2	1	
4	61217918	SELECTEUR 1 2	1	
5	61231339	FOURCHETTE 1 2	1	
6	61227197	COULISSEAU 3 4	1	
7	61218954	FOURCHETTE 3 4	1	
8	61227198	COULISSEAU AR	1	
9	61217917	SELECTEUR AR	1	
10	61217919	CULBUTEUR AR	1	
11	61227199	COULISSEAU RED	1	
12	61229460	FOURCHETTE RED	1	
13	61231061	VIS	6	
14	61700872	RESSORT	3	
15	61410661	BILLE	3	
16	61700869	DOIGT	3	
17	61217941	ENTRETOISE	1	
18	61229451	ARBRE	1	
19	61216548	LEVIER	1	
20	61406005	CLAVETTE	1	
21	61803111	VIS D8 L40	1	
22	61801011	ECROU DE 8	1	
23	61815224	GROWER DE 8	1	
24	61803112	VIS D 8 L 45	8	
25	61815224	GROWER DE 8	8	

6	7	8	9	10
26	61664984	CYLINDRE	1	
27	61400562	GOUJON	3	
28	61815225	GROWER DE 10	3	
29	61801012	ECROU DE 10	3	
30	61109337	CHAPE	1	
31	61216165	JOINT	1	
32	61235478	LEVIER	1	
33	61227602	PIVOT	1	
34	61251060	JOINT	1	
35	61701446	GOUPILLE	1	
36	61215448	PATIN	1	

10	11

10	11

02	53	203	00	04
1	2	3	4	5



DÉSIGNATION PLANCHE : SE RÉFÉRER AUX PAGES "SOMMAIRE"

PLATE DESIGNATION : REFER TO FLYLEAF

BILDBESCHRIFTUNG : SIEHE VORSATZBLÄTTER



6	7	8	9	10
1	61656712	CARTER ASS	1	
2	61222600	BAGUE	2	
3	61059577	PORTE	1	
4	61803071	VIS D6 L12	4	
5	61815303	EVENTAIL DE6	4	
6	61206044	PIED	2	
7	61218821	GOUJON	6	
8	61400865	RONDELLE	6	
9	61425034	ECROU	6	
10	61224753	TROMPETTE	1	
11	61231618	JOINT	1	
12	61215944	JOINT EP 03		68
13	61215945	JOINT EP 04		68
14	61215946	JOINT EP 05		68
15	61803109	VIS D 8 L 30	6	
16	61815224	GROWER DE 8	6	
17	61251472	BUTEE DEBRAYAG	1	
18	61225012	AXE	1	
19	61219272	FOURCHETTE	1	
20	61406005	CLAVETTE	3	
21	61803110	VIS D 8 L 35	1	
22	61400936	GROWER DE 8	1	
23	61208189	BAGUE	1	
24	61095998	GOUVILLE	1	
25	61225438	LEVIER	1	

6	7	8	9	10
26	61803112	VIS D 8 L 45	1	
27	61815224	GROWER DE 8	1	
28	61801011	ECROU	1	
29	61222601	CACHE	2	

10	11
0068	Quantités : au choix Quantities : as desired Mengen : nach Wahl

10	11

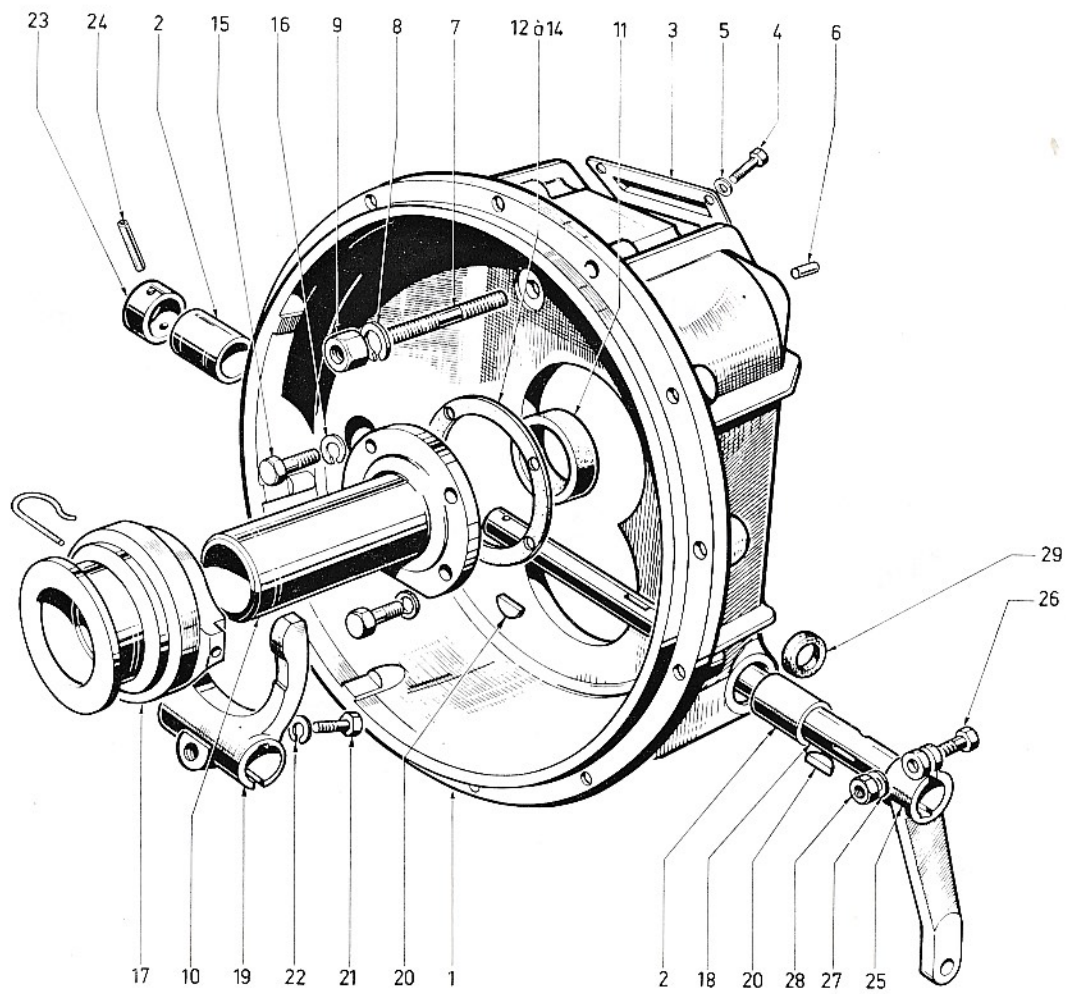

02	53	203	00	04
1	2	3	4	5

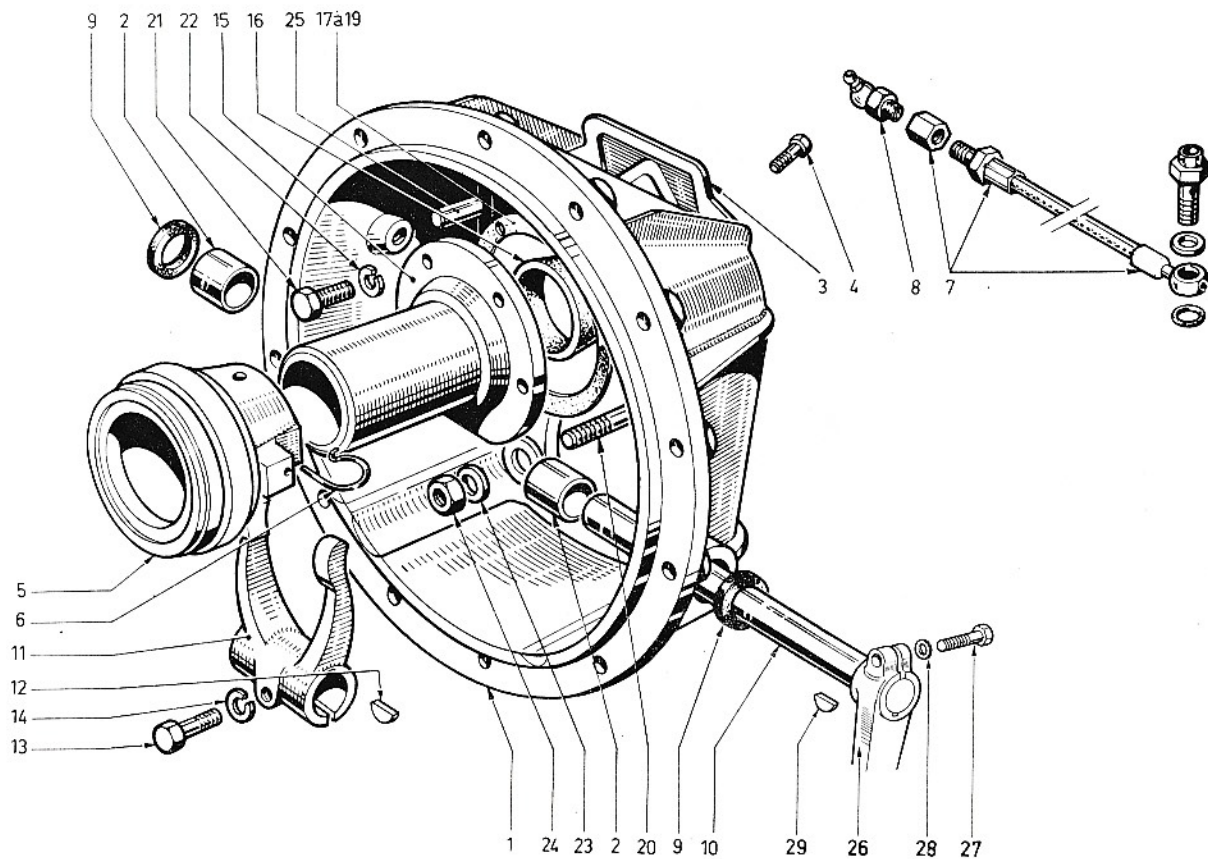

02	53	203	00	05
1	2	3	4	5

6	7	8	9	10
1	61662125	CARTER ASS	1	
2	61228492	BAGUE	2	
3	61700903	PORTE	1	
4	61803100	VIS D 8 L 10	2	
5	61662839	BUTEE DEBRAYAG	1	
6	61254999	CRAMPON	2	
7	61119384	FLEXIBLE	1	
8	61836035	GRAISSEUR	1	
9	61228543	CACHE	2	
10	61229630	AXE	1	
11	61229492	FOURCHETTE	1	
12	61406005	CLAVETTE	2	
13	61520072	VIS	1	
14	61400936	GROWER DE 8	1	
15	61224753	TROMPETTE	1	
16	61231618	JOINT	1	
17	61215944	JOINT EP 0 3		68
18	61215945	JOINT EP 0 4		68
19	61215946	JOINT EP 0 5		68
20	61218821	GOUJON	6	
21	61803109	VIS D 8 L 30	6	
22	61815224	GROWER DE 8	6	
23	61400865	RONDELLE	6	
24	61425034	ECROU	6	
25	61206044	PION	2	

6	7	8	9	10
26	61230472	LEVIER	1	
27	61803112	VIS D 8 L 45	1	
28	61815224	GROWER DE 8	1	
29	61406005	CLAVETTE	1	

10	11
0068	Quantités : au choix Quantities : as desired Mengen : nach Wahl

10	11